

ID TECHNOLOGY

L&C

LABELING
& CODING

265 WITH CARBONFLEX™ HIGH-SPEED PRINT & APPLY LABELING SYSTEM



Excellence in Secondary Packaging Labeling

The CarbonFlex applicator is engineered to apply one or two labels to shipping cases, shrink-wrapped trays, or pallets, when integrated with an ID Technology 265 or Panther Predator print and apply labeling system.

Safety, accuracy, and tolerance of product handling are all critical parts of the CarbonFlex concept.

The ID Technology 265 is the perfect match for CarbonFlex. With its sophisticated Allen-Bradley controls managing the CarbonFlex servo drive and easy-to-use touch-screen HMI ensuring happy operators, the 265 is the solution for many secondary packaging applications.

The 265 with CarbonFlex is also a good solution for pallet labeling - able to apply one or two labels without the pallet needing to stop.

FEATURES AND BENEFITS

- Designed to apply one or two labels to shipping cases, shrinkwrapped trays or pallets
- Allen-Bradley PLC controls
- Multiple communication protocols for line integration
- Servo-controlled, carbon fiber label application blade
- All-electric - no compressed air needed
- Less sensitive to inconsistent product handling than other applicator types
- Engineered for high-speed packaging lines
- Modular components for maximum serviceability
- Zero downtime option featuring redundant labeling heads for continuous labeling production
- Built-in safety - applicator reverses direction on contact and greatly reduces pinch points

COMMON APPLICATIONS



STANDARD PRODUCT SPECIFICATIONS

| | | | | |
|------------------------------------|---|--------------|-------------------|---|
| Label Supply | 14" Diameter / 3" Core | | Electrical | 120V AC @ 6A, 60Hz |
| Label Size | Min: 4" x 2" | Max: 6" x 4" | PLC | Allen-Bradley Micro850 |
| Standard Applicator Lengths | 12" / 18" / 24" | | Printer | Print Engines From Zebra & Sato |
| Operation | All Electric - No Compressed Air Required | | Conveyor | Optional Integrated Conveyors Available |

CONFIGURATION

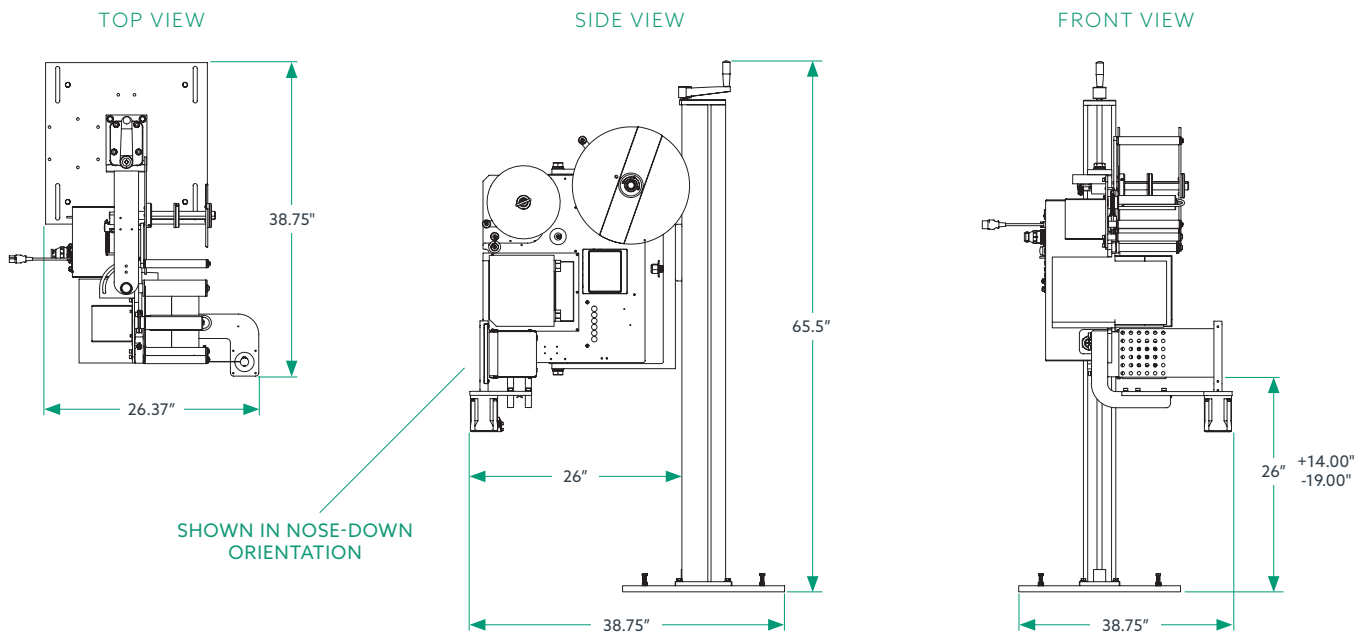

SYSTEM OPTIONS

- Low Label Sensor and Alarm Beacon
- Remote Mounted HMI
- Barcode Scanner
- Various Type of Mounting Hardware
- Integrated Conveyor
- NiceLabel Label Software
- ID Technology NiceLabel Custom Apps
- Windows Based IPC for NiceLabel
- Zero Downtime Option

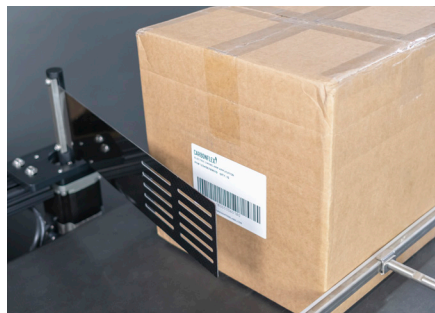

©2022 ProMach Inc. ProMach reserves the right to change or discontinue specifications and designs shown in this brochure without notice or recourse
PM_IDT_Spec Sheet_265 CarbonFlex_